

# MLT6SMDS

MOBILE LED LIGHT TOWER

**GENERAC** | **MOBILE**

## INCLUDES

- Generac G5 LED luminaires
- Painted mast for extended durability
- Large diesel fuel capacity for increased run time
- GFCI outlets for convenience power
- Two-handle mast winch for quick deployment
- 1,000 hr oil change interval for all versions
- CSA Certified
- Five Year LED Warranty
- Designed for easy service and maintenance

## FEATURES

- Rental Applications: Industry proven design.
- Test Criteria:
  - Prototype Tested
  - Cold Weather Tested
  - CSA Tested
  - Motor Starting Ability
- Diffused Lighting is available for highway applications (Optional)
- Heavy-Duty Trailer Design: DOT certified with leaf-spring suspension. Folding tongue reduces shipping and storage space.
- Set-up and Operation: Designed to be user-friendly and efficient for rental applications.
- Multiple Electric Power Convenience Outlets: To power external devices.
- G5 LED Lights: Super bright 320W LED luminaires.
- Fork Pockets: Quick and easy maneuvering, mobility, and transportability.
- Central Lifting Point: Unit can be lifted from above with a sling.



Picture shown may not reflect actual configuration.

## CODES AND STANDARDS

Generac Mobile products are designed to the following standards:



## LIGHT WHEN AND WHERE YOU NEED IT

Generac Mobile light towers are designed and engineered to illuminate a variety of projects, in the most extreme environments. Light towers are configured to meet customer needs.

Generac Mobile light towers are manufactured to deliver reliable power and light when and where you need it.

# MLT6SMDS

MOBILE LED LIGHT TOWER

**GENERAC**® | **MOBILE**

## STANDARD FEATURES

### ENGINE SYSTEM

- Mitsubishi® L3E
- Diesel fueled
- EPA Tier 4 Final
- 3 cylinder
- 0.95 L displacement
- Power @ 1,800 rpm – HP (kW):
  - Prime: 11.3 (8.4)
  - Standby: 12.2 (9.1)
- Air filter: Dry type cartridge

### FUEL SYSTEM

- Polyethylene tank
- Capacity: 39.9 gal (151.04 L)
- Run time – hr:
  - Lights only: 164\*
  - 100% load: 67\*
- Fuel consumption – gph (Lph):
  - Lights only: 0.2 (0.9)\*
  - 100% load: 0.6 (2.3)\*
- Fill port diameter: 3.5 in (89 mm)

### COOLING SYSTEM

- Liquid cooled

### LUBRICATION SYSTEM

- Oil filter: Full flow, spin-on type
- 1,000-hr service interval\*\*

### ALTERNATOR

- Marathon Electric® brushless
- 6 kW output
- 120/240 VAC, 20/30A
- ± 6% capacitor voltage regulation

### LUMINAIRES (LED)

- Four 320 W G5 LED fixtures
- Aluminum and polymer housing
- Efficiency: 155 lpw
- Lm/fixture: 49,600
- Total lm: 198,400
- Coverage at 0.5 ft-c: 30,020 ft<sup>2</sup> (2,779 m<sup>2</sup>)
- IP68 LED modules
- Fixture-mounted drivers

### ELECTRICAL SYSTEM

- 30A start trip breaker (ensures no-load condition exists at start-up)
- Floodlight circuits with sealed 10A breakers
- Convenience receptacles with individual breakers:
  - One 120 VAC, 20A, GFCI, duplex outlet (NEMA 5-20R type)
  - One 240 VAC, 30A, twistlock outlet (NEMA L14-30R type)
- Wiring is sized and fused to required amperage draw
- 440 CCA wet cell battery

### CONTROLS

- Illuminated control panel with sealed switches
- Key-activated switch with 4 positions (OFF, RUN, GLOW PLUG, START)
- One switch controls all light fixtures
- Digital hour meter
- Automatic shutdown for low oil pressure and high coolant temperature

### MAST

- Vertical operation and storage
- Four tubular steel sections with polymer guides
- Ground-adjustable light fixtures
- Winch: Dual handle, manual crank
- Distinctive angled fixture mount for common light distribution
- Rotation: 359° range of motion, adjustable from ground during full extension
- Industrial black powder-coat finish
- Self-retracting, coiled mast cord

### ENCLOSURE

- Hood: Injection-molded with UV protected colorant
- Flip-up design for ease of service
- Sound rating: 63 dB (A) at 23 ft (7 m) @ prime power
- Lifting point and fork pockets
- Multi-lingual operating and safety decals
- Illuminated license plate holder
- Document holder with owner's manual – includes AC and DC wiring diagrams

### TRAILER

- Tubular steel frame
- 2 in (50.8 mm) ball hitch
- Three 1,200 lb (544 kg) leveling jacks – lockable into stowed positions
- Folding tongue
- Side outriggers
- 7,800 lb (3,538 kg) safety chains with spring loaded safety hooks
- Transportation tie-downs
- DOT approved LED lights: Tail, side, brake, and directionals
- 2,200 lb (998 kg) leaf spring axle
- Tires: ST175/80, 13 in rim

### AMBIENT CLIMATE RATINGS

- Max wind speed: 65 mph (105 km/h)
- Max air temperature – °F (°C):
  - Lights only: 120° (49°)
  - 100% load: 104° (40°)

### WARRANTY

- 2 Years, 2,000 Hours (Unlimited Hours Covered in First Year)
- 5 Years Limited: LED Lights

### WEIGHT

- Dry: 1,310 lb (594 kg)
- Operating: 1,600 lb (726 kg)

# MLT6SMDS

## MOBILE LED LIGHT TOWER



### OPTIONS

- Electric Winch
- Positive Air Shutdown
- Tandem Tow
- Battery Charger
- Battery Disconnect
- Power Zone® Plus Controller
- Engine Block Heater
- Fuel Filter Heater
- 110% Oil and Coolant Containment

\* Temperature ratings depend on other environmental factors.

\*\*Data based on engine manufacturer and field test data after 100-hr engine break-in period. Actual results may vary, according to factors such as age and maintenance of equipment, environmental conditions, and fuel density. For fuel and maintenance recommendations, see owner's manual. To achieve maximum service interval, replace oil filter after 50-hr break-in period. For oil filter model number, see parts manual

### ILLUMINATION MAPS

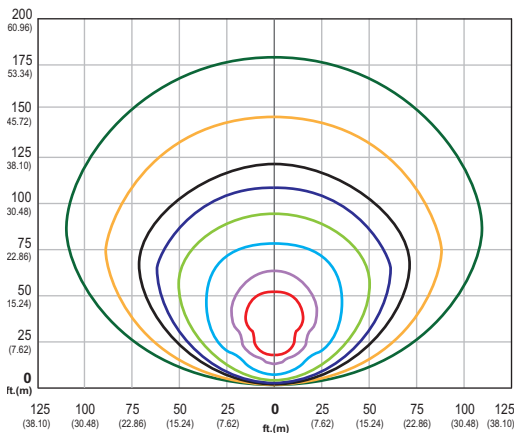

Ft² (m²)	
789 (73)	9,907 (920)
1,739 (162)	12,859 (1,195)
4,009 (372)	19,766 (1,836)
7,007 (651)	30,020 (2,789)

Standard Configuration  
70 Degree Tilt

0.5 FC CL Fwd Distance (Reach ft/m) 167/51  
0.5 FC Max Width (Spread ft/m) 219/67

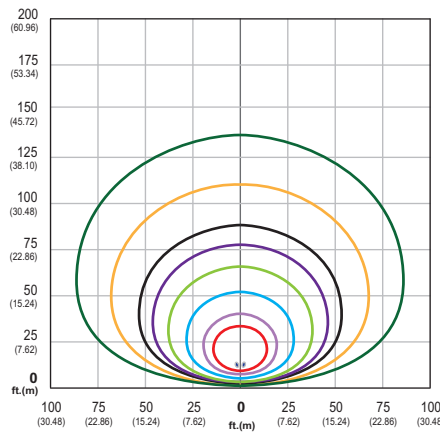

Ft² (m²)	
513 (48)	5,350 (497)
974 (91)	7,135 (663)
2,034 (189)	11,458 (1,065)
3,646 (339)	18,172 (1,688)

Diffuser Equipped  
70 Degree Tilt

0.5 FC CL Fwd Distance (Reach ft/m) 125/38  
0.5 FC Max Width (Spread ft/m) 171/52

#### KEY

- 30 foot candles (fc)
- 20 foot candles (fc)
- 10 foot candles (fc)
- 5 foot candles (fc)
- 3 foot candles (fc)
- 2 foot candles (fc)
- 1 foot candles (fc)
- 0.5 foot candles (fc)

# MLT6SMDS

MOBILE LED LIGHT TOWER

## ENGINEERING DATA

### MACHINE

Fuel tank capacity - total - US gal (L)	39.9 (154.04)
Total Run Time - lights only (hr)	164
Total lumens	198,400
Weight - Dry - lb (kg)	1,310 (594)
Weight - Operating - lb (kg)	1,600 (72)

### ALTERNATOR

Make	Marathon®
Model	201CSA5423
Frequency - Hz	60
Type	Brushless
Insulation Class	Class F
Output power at prime - (kW)	3.3
Output voltage - (VAC)	120/240
Output at 120 VAC (A)	20/30
Voltage regulation accuracy - %	±6
Voltage regulation	Capacitor

### ENGINE

Make (model)	Mitsubishi® (L3E)
Fuel	ASTM diesel fuel
EPA certification	T4F
Cylinders	3
Displacement - in <sup>3</sup> (L)	57.9 (0.95)
Power - Standby - hp (kW)	12.2 (9.1)
Fuel consumption - lights only** gph (L/hr)	0.2 (0.9)*
Fuel consumption - 100% load** gph (L/hr)	0.6 (2.3)*
Fuel tank material	Polyethylene
Oil Capacity - qt (L)	5.0 (4.7)
Oil Filter	Full flow, spin-on
Oil Filter Change Interval*** (hr)	1,000
Air Filter	Dry cartridge

### DIMENSIONS

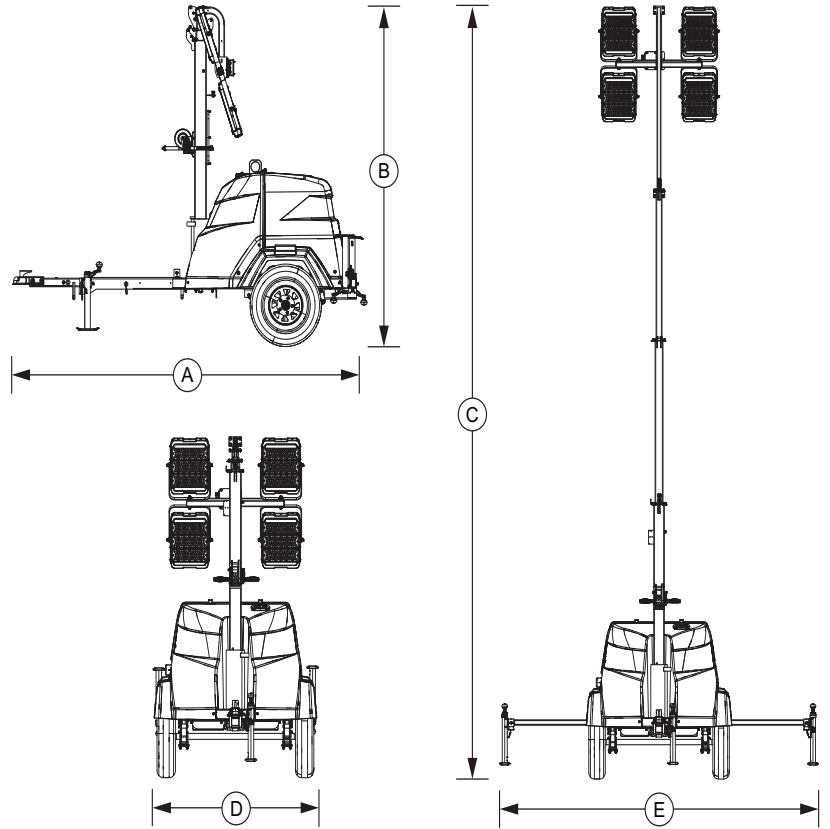

A	B	C	D	E
118.0 in	101.0 in	23 ft	57.0 in	120 in
3.0 m	2.6 m	7.0 m	1.45 m	3.05 m

\* All measurements are approximate and for estimation purposes only.

\* Temperature ratings depend on other environmental factors.

\*\* Data based on engine manufacturer and field test data after 100-hr engine break-in period. Actual results may vary, according to factors such as age and maintenance of equipment, environmental conditions, and fuel density. For fuel and maintenance recommendations, see owner's manual.

\*\*\* To achieve maximum service interval, replace oil filter after 50-hr break-in period. For oil filter model number, see parts manual.

**YOUR FACTORY RECOGNIZED GENERAC MOBILE DEALER**

Specification characteristics may change without notice. Dimensions and weights are for preliminary purposes only. Consult a Generac Mobile Authorized Service Dealer for detailed installation drawings