

### Includes

- Small footprint to reduce freight cost
- Easy to transport
- Rechargeable with standard 120V charging
- 20 Amp (5-20 plug)
- Built-in, maintenance-free AGM battery pack
- 3 x 400 Wp high efficiency solar panels
- Autonomous Operation with Dusk to Dawn scheduler
- Photocell-controlled auto-on/off
- 4 x 100 W high efficiency G4 LED lights by Generac Mobile
- Automatic and manual operating modes
- Intuitive control panel for rental friendly operation
- Low maintenance with no engine or alternator
- No fuel, no emissions, no noise
- Adjustable-tilt solar array
- Automatic solar charging
- Heavy-duty secure battery box
- Galvanized mast
- Easy to deploy solar panels
- One person setup & take down



### Codes and Standards

Generac Mobile products are designed to the following standards:



NATM

### Test Criteria

- Proven GENERAC Solar Design
- Prototype Tested
- Cold Weather Tested
- Hot Weather Tested
- Rain Tested
- Vibration Tested
- Finite Element Analysis (FEA)

### STANDARD FEATURES

---

#### CONTROLS

- Victron Controller (Cerbo GX)
- Dusk to Dawn functions via photocell
- Dusk to Dawn & Dusk +3, +6, +9
- Comprehensive warnings protect the operator and equipment

#### LUMINAIRES

- Four G4 100W LED fixtures
- Aluminum and polymer housing
- Efficiency : 150 LPW
- Lm/fixture: 15,000
- Total Lm: 60,000
- Coverage @ 0.5f-c: 21,070ft<sup>2</sup> (1,957 m<sup>2</sup>)
- IP68 LED modules, IP65 rated drivers
- Tool-free individual light positioning

#### ENCLOSURE

- Heavy-duty, 14-gauge steel for tough rental applications
- Stainless steel or zinc-plated hardware. Prevents oxidation and helps increase resale value.
- UV and fade resistant, white polyester powder paint.
- Salt-spray tested to 1,000 hours
- Side and rear fork pockets
- Document holder with owner's manual (Includes AC and DC wiring diagrams)

#### TRAILER

- Steel frame designed for stability.
- 3,300 lb capacity leaf-spring axle durable, with even weight distribution
- 4 Leveling and stability stabilizer jacks: 2 front, 2 back
- Wheeled jack on tongue for easy positioning of unit
- Single-wall polymer fenders durable and UV resistant
- LED trailer lights (side, brake, and directionals DOT approved)
- Illuminated license plate holder DOT approved
- Tires ST175/80, 13 in rim
- Heavy-Duty trailer design: DOT certified with leaf spring suspension
- 2 in ball hitch
- 4-pin flat trailer adapter

#### WARRANTY

- 1 year unlimited hours
- LED lights: 5 year, limited

### SPECIFICATIONS

#### General

Make (Model)	VT Solar
Units per 48' truck (Qty)	8
Lights	4 x 100W LED
Battery capacity	11,520 Wh
Brightness (25%)	78 hours
Brightness (50%)	39 hours
Brightness (75%)	26 hours
Brightness (100%)	19.5 hours
Light Dimmer Control	25 - 100% Infinite Variability
Batteries	AGM
Winch	Manual / Single Handle
Charging	120V/20A (5-20P inlet)
Charge Time (Shore power)	12.2 hours (0-100%)

#### Solar Panels

Type	Mono Crystal Silicon
Quantity	3
Wattage	3 x 400W
Tilt Angle	5-35° @5° increments

#### Mast

Height (ft/m)	21.3 ft (6.5 m)
Sections	5

#### Trailer

Tires	ST175/80, 13 in rim
Tow hitch	2.0 in ball
Finish	Powder coated
Suspension	Leaf spring (3,300 lb)
Forklift pockets	Yes - 2 sides and rear

#### Inverter

Brand	Vitron MultiPlus II 120V
Model	48/3000/35-50
Input Voltage Range	38-60 VDC
Output Voltage	120 VAC, 60 Hz
Max Efficiency	95%

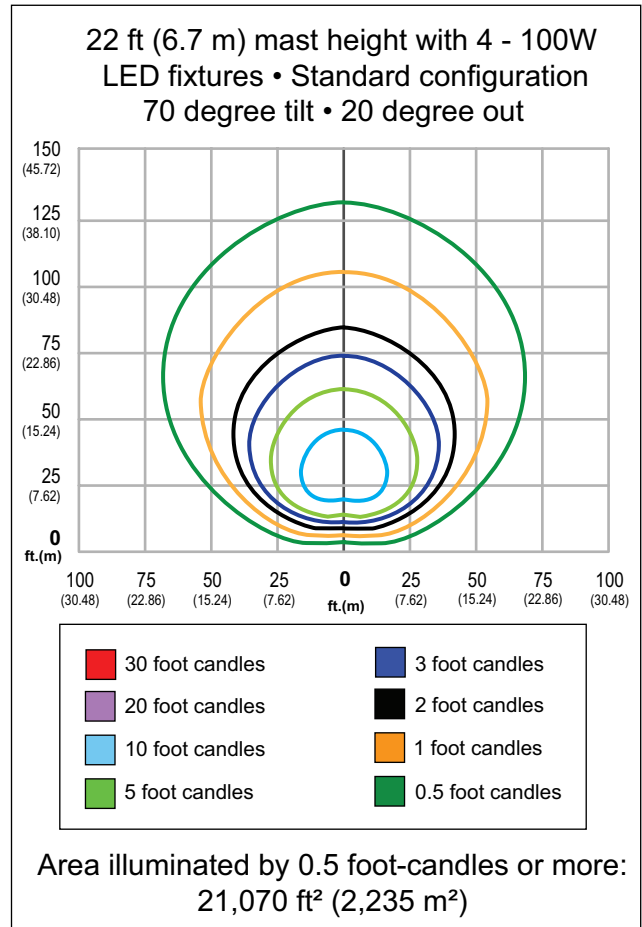

**DIMENSIONS AND WEIGHTS\***

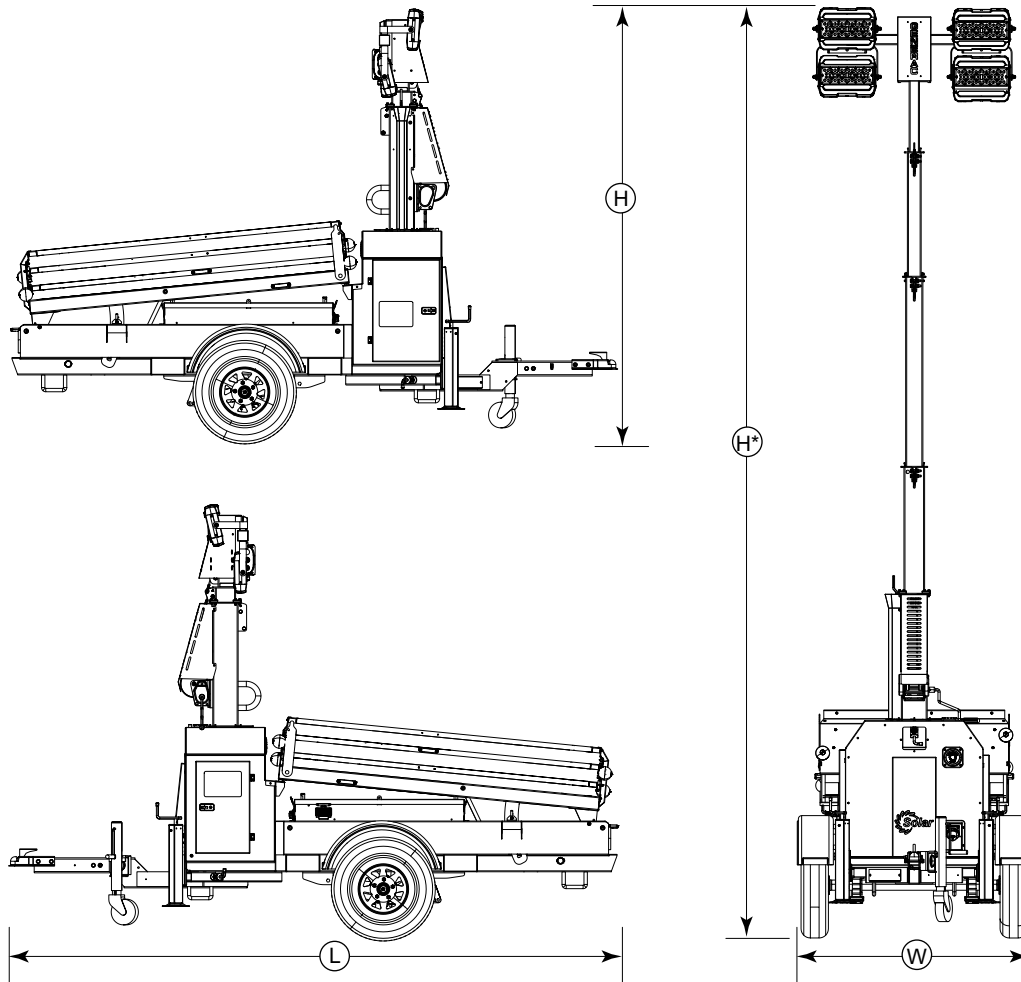

Dimensions	
L x W x H	142 in (3.61 m) x 54 in (1.37 m) x 99 in (2.51 m)
L x W x H*	142 in (3.61 m) x 54 in (1.37 m) x 21.3 ft (6.50 m)
Weight	2,401 lbs (1089 kg)

\* All measurements are approximate and for estimation purposes only.

**YOUR FACTORY RECOGNIZED GENERAC MOBILE DEALER**

Specification characteristics may change without notice. Dimensions and weights are for preliminary purposes only. Please consult a Generac Mobile Authorized Service Dealer for detailed installation drawings.